

AIR HANDLER
14 SEER

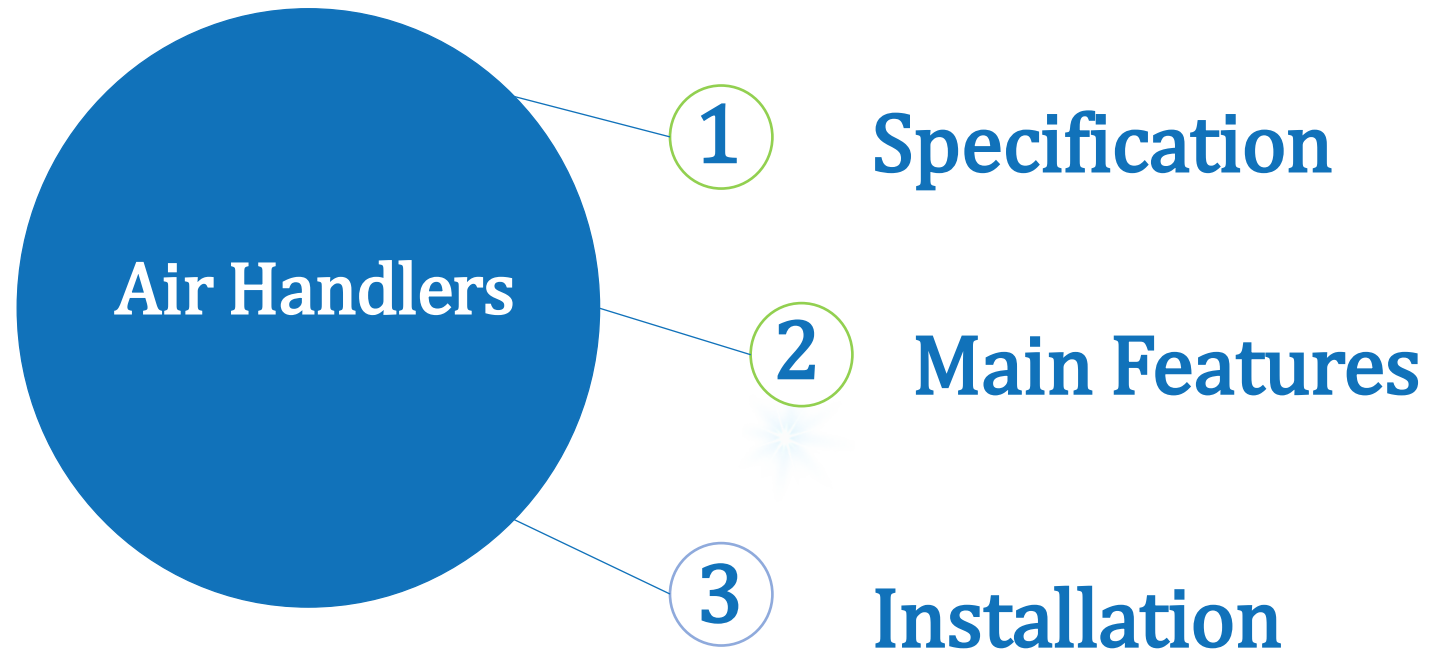



Air Handler



Specification (SEER14 Cooling only)



Model	Cooling Capacity (Btu/h)	SEER	Indoor External Static pressure (pa)	Indoor Air Flow (CFM)	Indoor Unit Dimension (WxHxD) (inch)	Packing Dimension (WxHxD) (inch)	Indoor Noise Level dB(A)
CAH4-18MBEP1-14	18000	14.00	25	802/723/650	20×46×22	22×47×25	40
CAH4-24MBEP1-14	24000	14.00	25	938/804/738	20×46×22	22×47×25	42
CAH4-30MBEP1-14	30000	14.00	37	1204/919/919	20×46×22	22×47×25	48
CAH4-36MBEP1-14	36000	14.00	37	1376/1235/1161	20×46×22	22×47×25	51
CAH4-42MBEP1-14	42000	14.00	37	1562/1542/1385	20×46×22	22×47×25	54
CAH4-48MBEP1-14	48000	14.00	50	1695/1574/1434	22×55×24	25×56×27	55
CAH4-60MBEP1-14	57000	14.00	50	1695/1574/1434	22×55×24	25×56×27	55

Specification (SEER14 Heat pump)



Model	Cooling Capacity (Btu/h)	SEER	Indoor External Static pressure(pa)	Indoor Air Flow(CFM)	Indoor Unit Dimension (WxHxD) (inch)	Packing Dimension (WxHxD) (inch)	Indoor Noise Level dB(A)
CAH4-18MBEP1-14	18000	14.00	25	802/723/650	20×46×22	22×47×25	40
CAH4-24MBEP1-14	24000	14.00	25	938/804/738	20×46×22	22×47×25	42
CAH4-30MBEP1-14	30000	14.00	37	1204/919/919	20×46×22	22×47×25	48
CAH4-36MBEP1-14	36000	14.00	37	1376/1235/1161	20×46×22	22×47×25	51
CAH4-42MBEP1-14	42000	14.00	37	1562/1542/1385	20×46×22	22×47×25	54
CAH4-48MBEP1-14	48000	14.00	50	1695/1574/1434	22×55×24	25×56×27	55
CAH4-60MBEP1-14	57000	14.00	50	1695/1574/1434	22×55×24	25×56×27	55

Main Features



❑ Cabinet

Galvanized steel, with powder paint on all panels.

❑ Coil

"A" shape coils, constructed with copper tubing and enhanced aluminum fins.

❑ Expansion device

Use piston as expansion device(13 SEER air handler)

Use TXS as expansion device(14 SEER air handler)

❑ Drain Pan

Durable noncorrosive plastic drain pans.

❑ Drainage design

Primary and secondary drainage design.

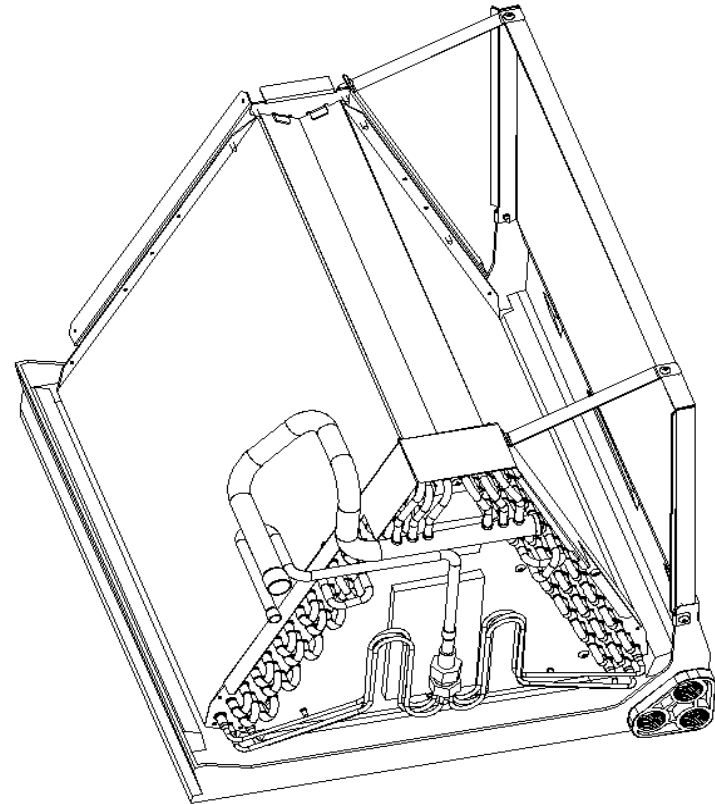

Main Features

□ Motor

Direct drive motors, 3-speed, provide selections of air flow to meet desired applications.

□ Blower

Φ10.8'' big fan, powerful wind.

Slide out blower assembly for easy maintenance.

□ Multi-position installation

Versatile 4-way convertible design for vertical up airflow,, horizontal right airflow.

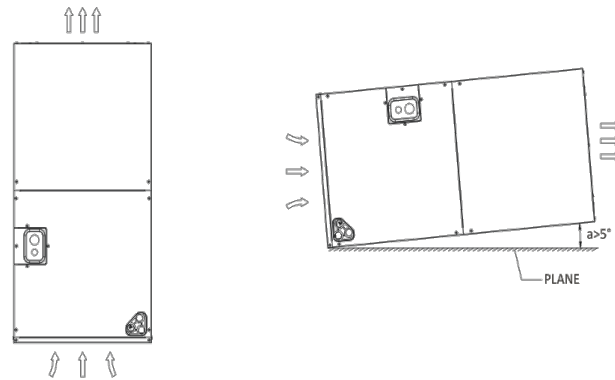

Main Features

❑ Filter optional

Detachable air filter for cleaning or renewal.

❑ Control

24V control, time delay relay, fan relay and transformer included.

❑ Certificate

Certified in accordance with ARI 210/240 standards,
ETL listed for electrical safety.

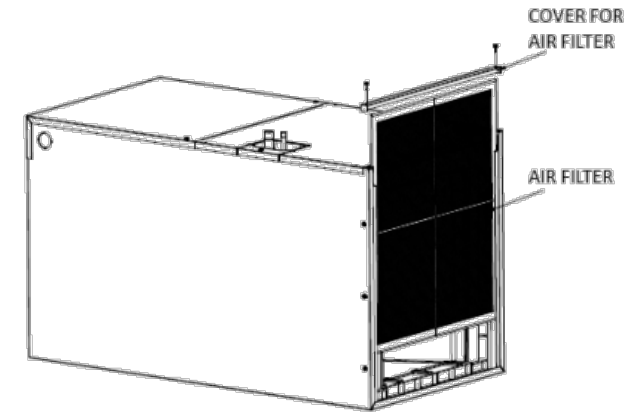

Installation

□ Ductwork

Model	Dimensions	
	D	E
18	414	245
24	414	245
36	414	245
48	454	266
60	454	266

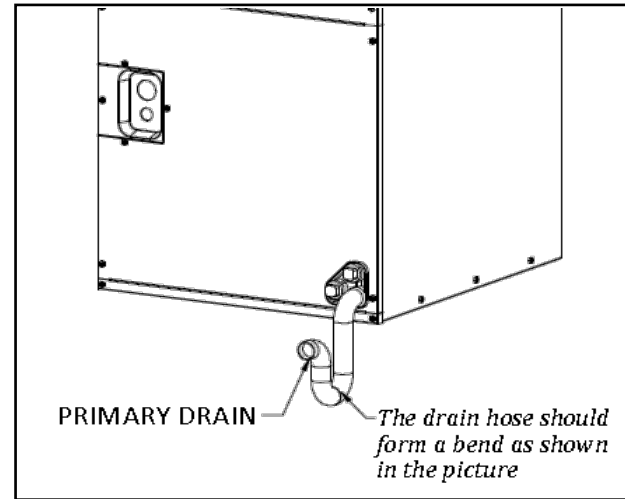
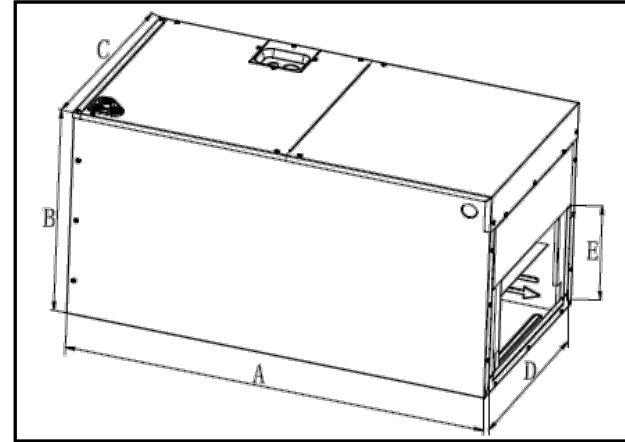

□ Condensation Drain Tubing

Make sure the unit is level or slightly ;

Toward primary drain connection;

Install a 3-inch trap;

Drain plugs are provided as accessories

Thanks